

ICON Round

Bathroom Mirror Installation & User Guide

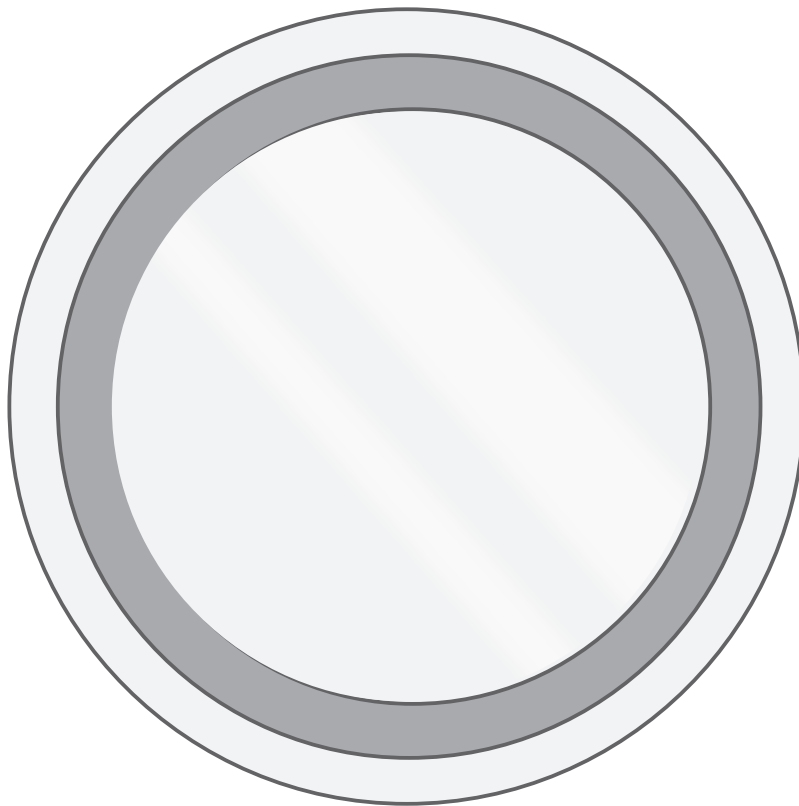



DANGER

Risk of personal injury. To avoid possible electrical shock, the electricity must be turned off at the circuit breaker or fuse box before attempting any installation procedure. The mirror must also be properly grounded.

To reduce the risk of burns, fire, electric shock or injury to persons. Use this furnishing only for it's intended use as described in these instructions. Do not use attachments not recommended by the manufacturer. Never drop or insert any object into any opening. Do not use outdoors.



GROUNDING INSTRUCTIONS

This product must be connected to a grounded metal, permanent wiring system, or an equipment-grounding conductor must be run with the circuit conductors and connected to the equipment-grounding terminal or lead on the product.

WARNING

- All fittings must be installed in accordance with current IEE wiring regulations. If in doubt, consult a qualified electrician.
 - Switch off the electrical supply at the main circuit board BEFORE installation and maintenance.
 - Suitable for Bathroom Zones 2, 3 and non bathroom/dry areas. See diagram below.
 - NOT suitable for above baths or Zone 1 nor for installation in Saunas, Steam Rooms or Shower Cubicles.
 - Suitable for indoor use only.
 - DO NOT fix to damp or conductive surfaces.
 - Site well away from curtains and fabrics.
 - Never cover the mirror.
- Switch off after use.

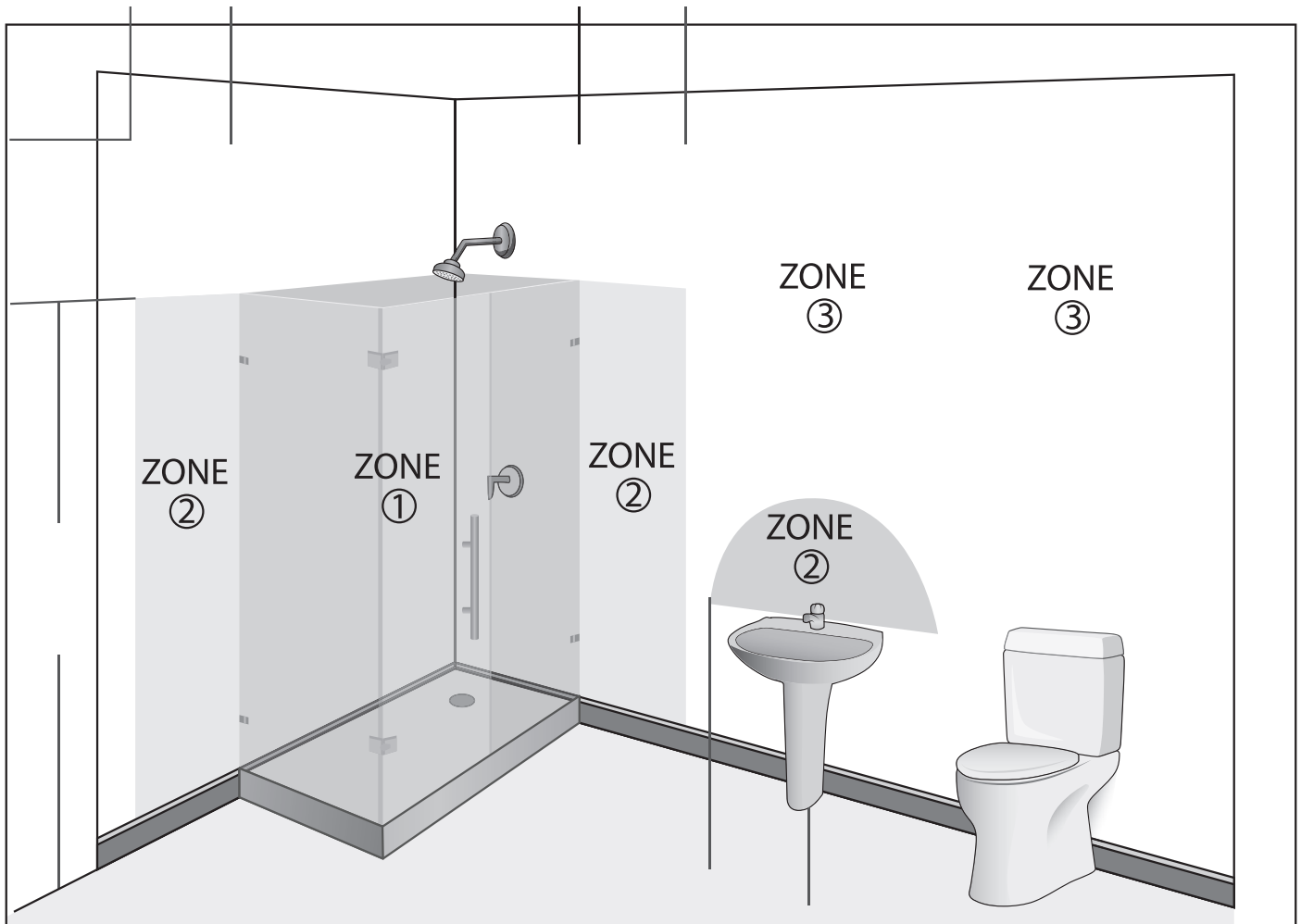

IMPORTANT—BEFORE YOU BEGIN

- Inspect the product immediately upon receipt for transit damage or missing parts.
- Handle the product with care and protect against knocks to all sides and edges of the glass.
- Make sure that you have all the tools you need to complete the job. (SEE BELOW)
- Ensure there are no hidden pipes or cables in the wall before drilling.
- If drilling holes in ceramic tiles use a piece of masking tape on the tile to stop the drill bit from slipping.

Aftercare Instructions

- Clean using a soft dry cloth only when turned off.
- Never use cleaning agents or abrasive materials.
- Do not allow moisture to come into contact with lamps.

TOOLS USED

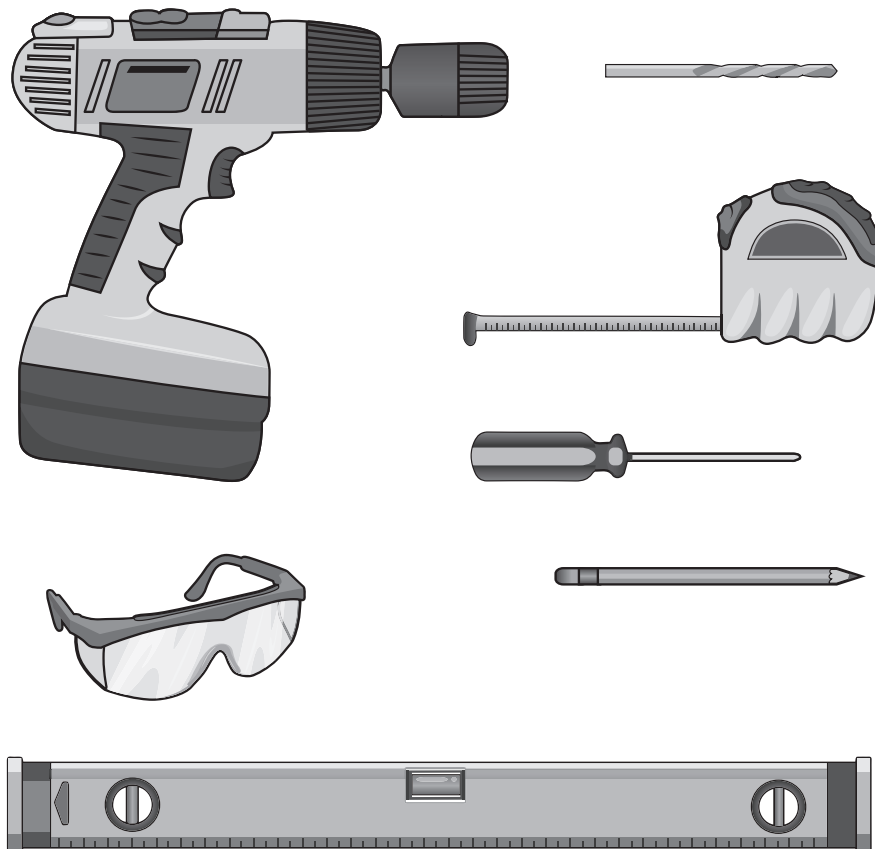

ELECTRICAL WIRE INFORMATION

The Lead Contains 3 Wires:

COPPER WIRE (GREEN) = GROUND WIRE...Connect to *GROUND WIRE* in your box, or to the box as a ground.

WHITE (or BROWN) = NEUTRAL WIRE...Connect to the *WHITE NEUTRAL WIRE* in your box.

BLACK (or BLUE) = HOT WIRE...Connect to the *BLACK HOT WIRE* in your box.

The Icon wires will be connected to your 110 Volt electric box. This should be placed in the wall, behind your Icon Mirror. The suggested method for placement is towards the center, however there is flexibility with the lead wire.

Please follow below illustrations

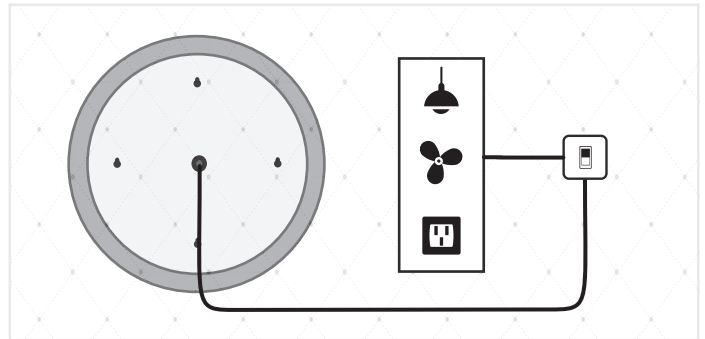
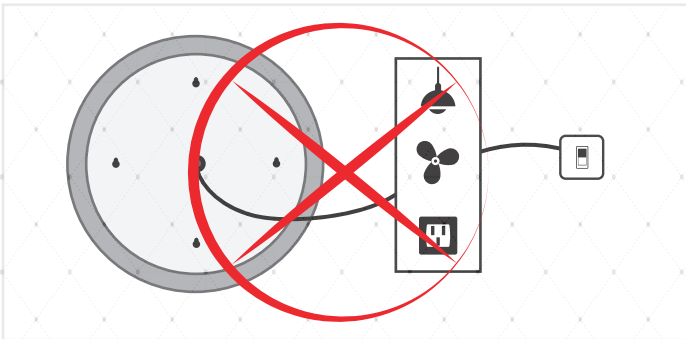

*Install optional outside switch to control the defogger
Refer to how to use guide for more information*

You CANNOT use an outside dimmer with the mirror

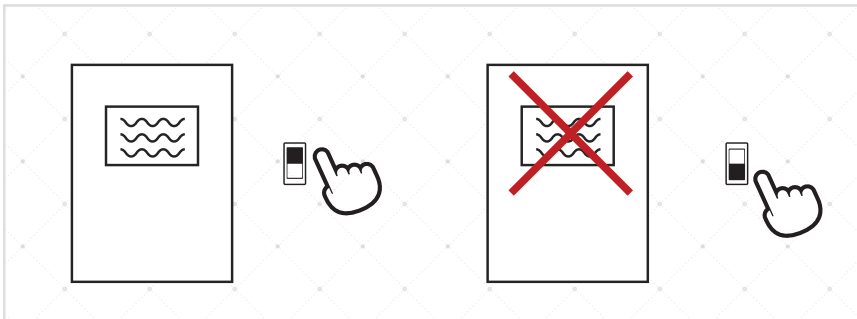

INSTALLATION GUIDE

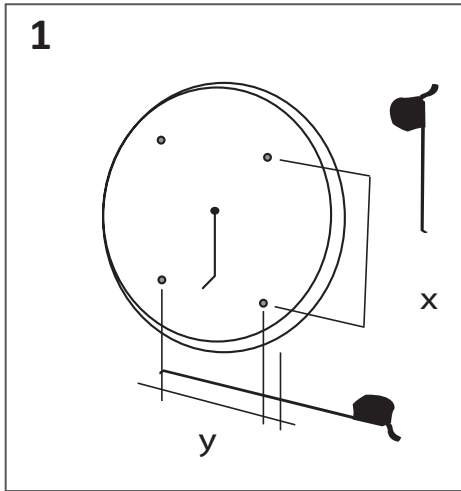

1
Measure distance between anchor positions

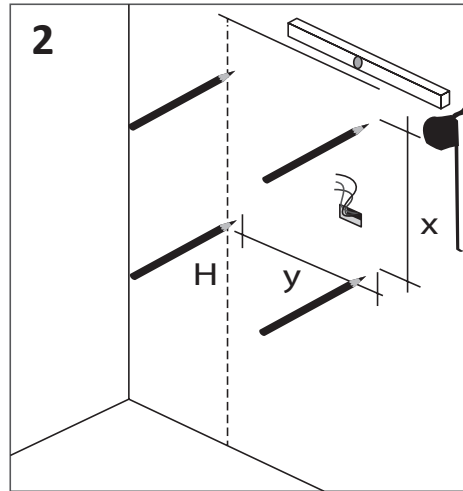

2
Mark hole positions on the wall ready for drilling

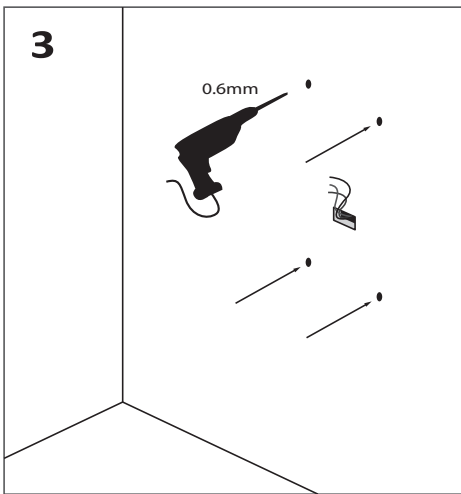

3
Carefully drill each of the holes

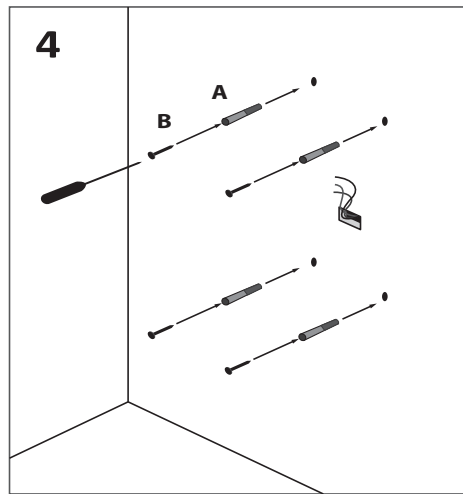

4
Insert anchors into predrilled holes

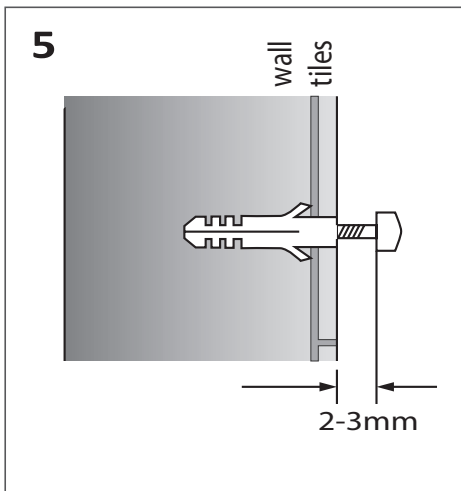

5
Drive in the screws leaving 2-3mm showing

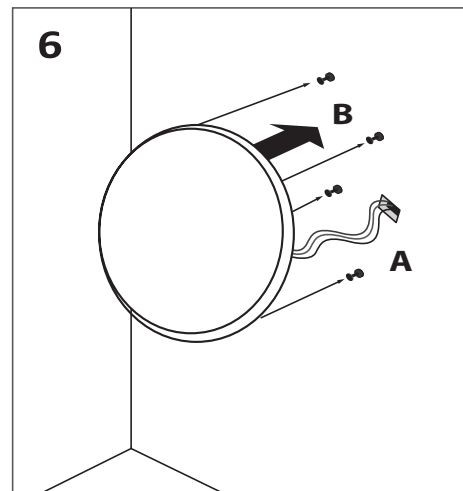

6
Hang the mirror with care onto the screws making sure it's secure

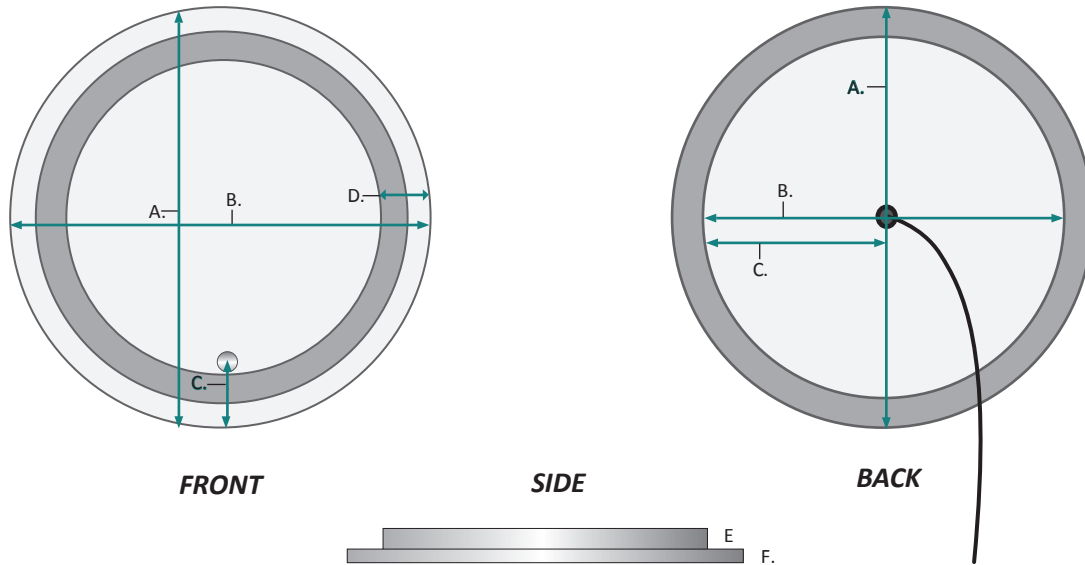

FRONT & SIDE

MODELS	A	B	C	D	E	F	ELECTRIC CURRENT	WATTAGES
853962007286	24	24	5	2	1-1/2	1/4	0.25A	30W

BACK

MODELS	A	B	C
853962007286	24	21-1/2	10-3/4

USE AND MAINTENANCE

- The interior is constructed of mirrored glass and aluminum. Use only a damp cloth to clean. Ammonia or vinegar-based cleaners can damage mirrors.
- When cleaning, spray the cloth, not the mirror, or surrounding surfaces. Do not use abrasive cleansers on any part of the light fixture.

LIMITED WARRANTY

Subject to the terms and conditions specified herein, Krugg Reflections USA LLC, (“KRUGG”) hereby extends a limited lifetime warranty (this “Limited Warranty”) to original Purchasers (as defined below) of the Krugg LED Medicine Cabinet (the “Product”) with respect to certain specified components of the Product. Specifically, KRUGG, by this Limited Warranty, warrants that, for the durations specified herein, Products purchased directly from KRUGG or KRUGG’s authorized retailers will be free of defects in the material and workmanship of the Product’s electrical components, glass, mirrors, and certain mechanical components, which defects would cause the Product to substantially fail to function when subject to normal use.

COMMERCIAL WARRANTY

Subject to the terms and conditions specified herein, Krugg Reflections USA LLC, (“KRUGG”) hereby extends a limited one-year warranty (this “Limited Warranty”) to Commercial Purchasers (as defined below) of the Krugg LED Lighted Mirror (the “Product”) with respect to certain specified structural components of the Product. Specifically, KRUGG, by this Limited Warranty, warrants that, for a one-year period, Products purchased directly from KRUGG or KRUGG’s authorized retailers will be free of defects in the material and workmanship of the Product’s electrical components, glass and mirrors, which defects would cause the Product to substantially fail to function when subject to normal use.

Additional Warranty Information can be found @ <http://www.kruggusa.com>
For any installation and warranty related issues, contact us at info@kruggusa.com